

# FILTERING DEPUROIL

## DEPUROIL

**EN.** Filter and transfer unit. DEPUROIL is the ideal tool for decontaminating oil by removing suspended particles. Fitted with a constantly operating volumetric pump which sends the fluid through a high-filtering capacity cartridge filter. Manometer for detecting clogged filter. Wheeled support. Noise level under 70 dB. Interchangeable cartridge filter with head. Supplied with a series of spare cartridges.

**ES.** Unidad de filtrado y trasiego. El DEPUROIL es un equipo ideal para descontaminar el aceite de partículas en suspensión. Dotado de bomba volumétrica, con funcionamiento continuo, que aspira el fluido enviándolo a un filtro con cartucho de elevada capacidad de filtración. Manómetro para controlar la obstrucción del filtro. Soporte sobre ruedas. Nivel de ruido inferior a 70 dB. Filtro con cartucho con parte superior intercambiable. Se suministra de serie un cartucho de repuesto.

**RU.** Блок для фильтрации и перекачивания. DEPUROIL представляет собой идеальное приспособление для очищения масла от взвешенных частиц. Устройство оснащено объемным насосом непрерывного действия, который всасывает жидкость, пропуская ее через патронный фильтр с высокой фильтрующей способностью. Манометр для проверки засорения фильтра. Опора с тележкой. Уровень шума ниже 70 дБ. Сменный патронный фильтр с головкой. Поставляется набор запасных фильтрующих патронов.

## DIMENSIONS

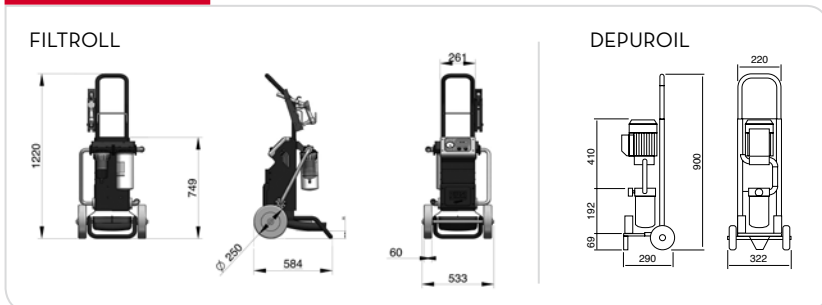

## PRODUCTS' RANGE WEIGHT AND PACKAGING

Code	Weight		Packaging		
	kg	lbs	mm	inch	pcs/box
<b>FILTROLL</b>					
F00506000	35	77,2	790x590x590	31,1x23,2x23,2	1
F00506010	42	92,6	790x590x590	31,1x23,2x23,2	1
F0050606A	40	88,2	790x590x590	31,1x23,2x23,2	1
<b>DEPUROIL</b>					
00050300A	28	61,7	600x290x300	23,6x11,4x11,8	1
F0050302C	28	61,7	600x290x300	23,6x11,4x11,8	1



Flow-rate

up to  
**25** l/min  
(up to 6,6 gpm)



DEPUROIL

DISPENSERS

PUMPS

METERS

NOZZLE METERS

NOZZLE

SPECIAL EQUIPMENTS

FLUID MONITORING

HOSE REEL

FILTERING

ACCESSORIES

FEATURES



Two step filtration

Oil/diesel version

FEATURES

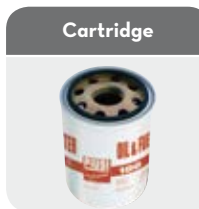

Cartridge



Foot filter



Pressure Gauge

PRODUCTS' RANGE TECHNICAL DATA

Code	Description	Fluids type	Flow-rate		Voltage			Pump type	Hose lenght		Filtering capacity $\mu$
			l/min	gpm	AC V./Hz DC Volt	Power Watt	Amp. max.		delivery m/ft	suction m/ft	
<b>FILTROLL</b>											
F00506000	Filtroll Diesel	D	56	14.8	230/50-60	350/600	3/6	Panther 56	4 / 13,1	3 / 9,8	30/5
F00506010	Filtroll Oil/Diesel	D O	25	7	230/50	750	4,6	Viscomat 70	3 / 9,8	3 / 9,8	30/5
F0050606A	Filtroll 12V Diesel	D	56	14.8	12	300	35	Panther DC	4 / 13,1	4 / 13,1	30/5
<b>DEPUROIL</b>											
00050300A	Depuroil M 230/50	O	20-25	5,28-6,6	230/50	1350	6,2	Viscomat 70	2 / 6,5	2 / 6,5	10
F0050302C	Depuroil 110/50-120/660	O	25	6,6	110/50-120/60	820/850	10-9	Viscomat 70	2 / 6,5	2 / 6,5	10
F00503100	Depuroil 60		50	13	230/50	1350	6,2	Viscomat 90	2	2	10

FILTROLL: Available in version 230 V / 60 Hz, 120 V / 60 Hz

DEPUROIL: Upon request it is available with different voltage and 60 Hz frequency