

# SPECIAL EQUIPMENTS CAMBIAOLIO

**EN.** The “Cambiaolio” satisfies the ever-increasing demand of extracting used oil from cars directly through the dipstick holder. Trailer-mounted support. Self priming pump.

**ES.** “Cambiaolio” responde a la exigencia cada vez más frecuente de extraer el aceite agotado de los automóviles directamente por el alojamiento de la varilla de control del nivel de aceite. Soporte sobre ruedas. Bomba autocebante.

**RU.** Устройство “Cambiaolio” отвечает становящейся все более актуальной потребности в откачивании отработавшего масла автомобиля непосредственно из гнезда щупа для проверки уровня масла. Опора с тележкой. Самозаливающийся насос.

## PERFORMANCE

- Continuous operation.
- Noise less than 70 dB.

- *Funcionamiento continuo.*
- *Ruido inferior a 70 dB.*

- Непрерывное функционирование
- Уровень шума ниже 70 дБ

## DIMENSIONS

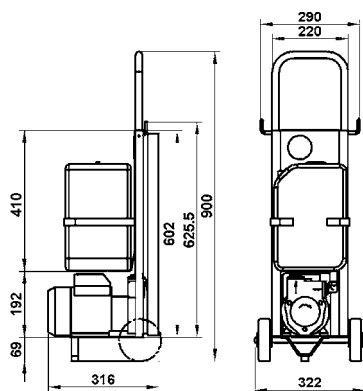

## PRODUCTS' RANGE WEIGHT AND PACKAGING

Code	Weight		Packaging		
	kg	lbs	mm	inch	pcs/box
F0050000B	19,5	43	600x290x300	23,6x11,4x11,8	1
00050006A	19,5	43	600x290x300	23,6x11,4x11,8	1



Flow-rate

up to  
**10** l/min  
(up to 3 gpm)

**PIUSI**<sup>®</sup>

**E**ASY TO USE



Cambialio



**INCLUDED**

**Probe Kit included:**

- 1 semi-rigid probe Ø 6 x 800 mm
- 1 semi-rigid probe Ø 8 x 800 mm
- 1 rigid probe Ø 8 x 650 mm
- 1 rigid probe Ø 9 x 650 mm



**FEATURES**

Pressure Gauge



Tank 10 liter



On/off switch



**PRODUCTS' RANGE** TECHNICAL DATA

Code	Description	Fluids type	Flow-rate		Voltage			Tank	
			l/min	gpm	AC V./Hz DC Volt	Power Watt	Amp. max.	liter	gal
<b>F0050000B</b>	Cambialio M	☐	2 - 10	0,5 - 2,5	230/50-60	350	2	10	3
<b>00050006A</b>	Cambialio 120V / 60 Hz	☐	2 - 10	0,5 - 2,5	120/60	1200	12,7	10	3

DISPENSERS

PUMPS

METERS

NOZZLE  
METERS

NOZZLE

SPECIAL  
EQUIPMENTS

FLUID  
MONITORING

HOSE  
REEL

FILTERING

ACCESSORIES